

# **HYDRONIC CORPORATION**

**Air Driven Hydraulic Pumps, Power Units and Intensifiers**

## **P901 Installation, Use and Maintenance Manual**

### **Contents**

**Introduction, Guarantee and Identification Plate**

**Description, Startup Procedures**

**Description of Working Parts, Storage and Disposal**

**Fault Finding, Maintenance and Weights**

**Spare Parts**

**Assembly Drawing**

Hydronic Corporation, 2034 Fruit St, Algonac, MI 48001 United States of America

 (810) 794 4935 [www.hydroniccorp.com](http://www.hydroniccorp.com)

## **Introduction**

This handbook is intended to give the operator the basic instructions for the use and maintenance of the pump. The air hydraulic pump operator must read this handbook before putting the pump into operation. After correctly installing the pump, keep this manual stored in a safe place. If you have difficulty in understanding any part of this handbook, contact Hydronic Corporation. Regular servicing and correct uses of the pump are fundamental in obtaining optimum performance over its life. When contacting our service center, specify the pump model and serial number; this will help us to respond quickly and effectively.

## **Guarantee**

Hydronic pumps are guaranteed both for the quality of materials used and for overall design. The warranty runs for six months of normal use at eight hours per day and five days per week. The warranty itself does not cover seals or defects arising from operation with unsuitable fluids or at pressures above the specified maximum. The guarantee cannot cover pumps that may have been tampered with. Defective goods must be sent to Hydronic Corporation, Michigan, or to the distributor covering the area, freight pre-paid in either case. Any pump returned to us must be accompanied by a full written description of such faults or defects as have been discovered. Please also ensure that the pump's serial number is attached to the paperwork.

Identification Plate shows:

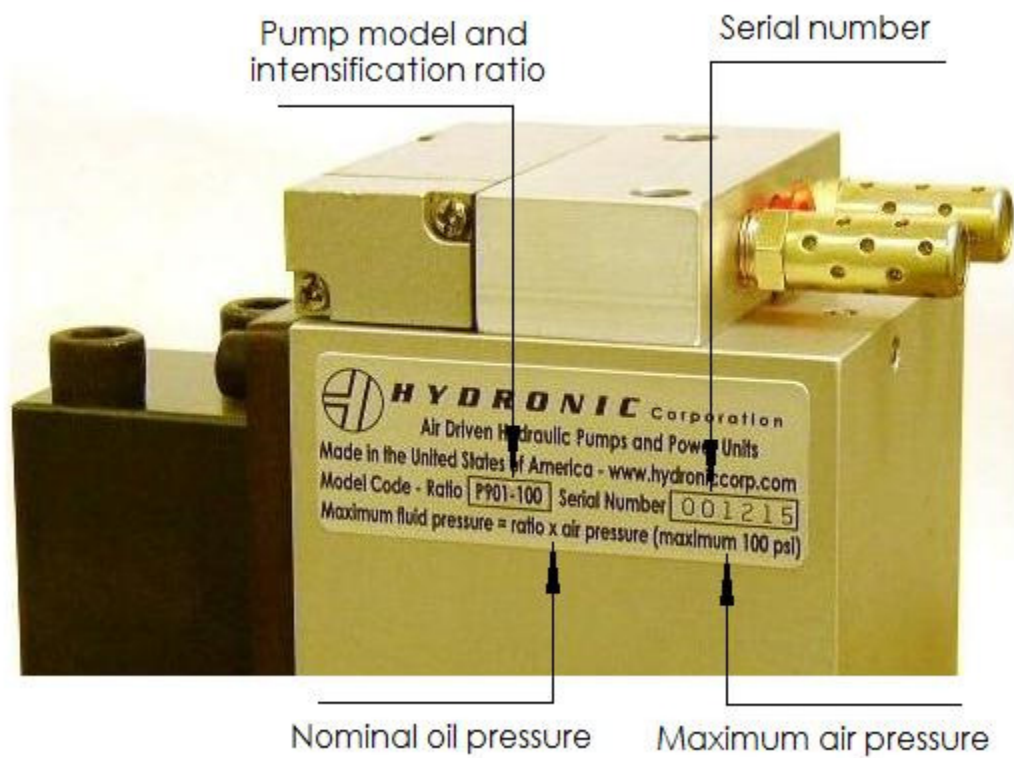

## Description and Start Up Procedures

Pumps may be installed in a horizontal, vertical or compound position for optimum functioning of the suction and pressure outlet check valves. Be sure that suction lines from the manifold to the hydraulic fluid are as straight as possible and do not have high points to trap air. Suction lines should be at least ¼" inside diameter and steps should be taken to ensure the hydraulic fluid is kept commercially clean. The air inlet connection should have piping of at least 1/8" bore and be kept to the shortest length possible to keep pressure losses to a minimum. **These operations should be carried out by qualified personnel.**

It is advisable to use or maintain:

- Hydraulic oil having viscosity of 150 to 250 SSU
- Oil temperature 32° F to 150° F
- Air temperature 40° F to 100° F

Obstructive icing of the muffler and/or breather may occur under certain temperature/humidity conditions. This should be taken as a sign that the pump is being used at an unacceptably high average duty. The remedy is to use two pumps combined at the fluid outlet (either of the same ratio or of a high flow ratio/high pressure ratio combination) or another Hydronic pump of a larger horsepower rating.

## Compressed Air System

It will be advisable to fit an air filter/regulator unit having maximum flow capacity of at least 5 scfm. Use tubing of at least ¼" inside diameter to avoid pressure losses.

## Hydraulic System

Valves, pipes, hoses and accessories should all correspond to maximum working pressure of the pump in order to ensure the **safety of all persons** nearby. Components should always be of a size that will fulfill flow requirements without unnecessary pressure losses.

## Priming and Initial Operation

After connecting the pump to air and oil circuitry, loosen the first hydraulic connection to allow entrapped air to bleed out. Allow the pump to operate with 20 PSI air pressure until the oil flows from the loose joint and then tighten the joint. Always observe strict safety and protection during this operation. Adjust settings until smooth operation is achieved.

## Principles of Operation

Hydronic Corporation's air driven hydraulic pumps are designed for operating oil hydraulic circuits and to cover the widest range of requirements to the best advantage.

The pump itself operates quite simply, using a known pressure intensification principle. A piston with a large surface area is actuated by compressed air. Attached to it is a piston with a smaller surface area, which is driven in a hydraulic chamber generating a high level of hydraulic pressure. The continuous pumping action is produced by compressed air being switched alternately to the top and bottom of the air piston by a valve. By regulating the compressed air supply pressure from 20 psi to 100 psi, the maximum hydraulic pressure can be adjusted using the ratio of the pump. As the hydraulic load from the circuit increases and the oil pressure rises, the pump will slow down and eventually stop. In this way, the maximum load of the circuit will be maintained without air consumption.

## Storage

If the pump is to be kept out of use for a long period, clean the pump in general and lightly oil inside and outside to prevent corrosion. Cover the pump and store it in a dry, well-protected place. It is advisable to wrap the pump in a plastic film. To put the pump back into service, check all parts, fill tank with oil and try the pump out to ensure that it working properly. **This operation must be carried out by qualified personnel.** Refer to the startup procedures for correct priming sequences.

## Disposal

If the pump is to be scrapped, treat as special waste. Dismantle it and divide it into materials of the same type and dispose of them in accordance with the local laws and regulations in your state.

### Air Operated Pressure Release Valve

This accessory is intended for use in systems where no directional control valves are used. Pressurized oil from the system will be released internally back to tank when pilot air pressure is applied to the 1/8" NPT connection shown here as B.

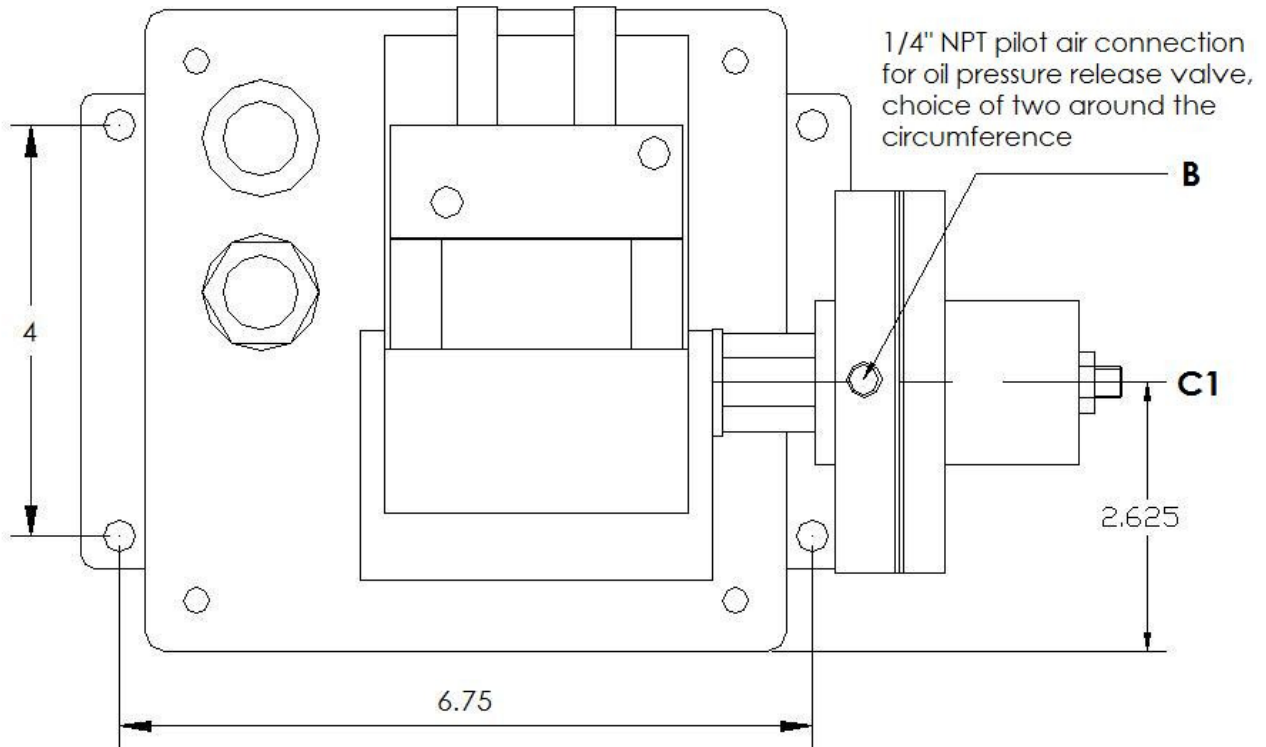

A small pneumatic valve can be used to direct regulated air pressure either to the pump or to the pressure release valve. This allows the power unit to be controlled remotely by the operator. The adjustment C1 may be needed when the pilot air pressure is low or if the required oil pressure is at the highest level. Adjusting the screw inward will hold the valve shut with more force but will also require more pilot air pressure to release it. A typical circuit is as follows:

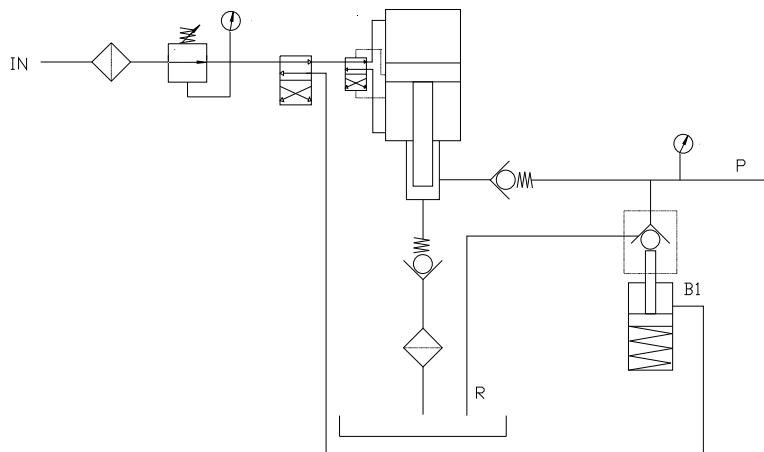

## Description of the Standard Pump Components

- A Air Cylinder
- B Air Valve
- C Air Inlet 1/8" NPT
- E Air Muffler
- F Oil Chamber Interface
- G Oil Suction Inlet Gallery
- H Oil Pressure Outlet Gallery

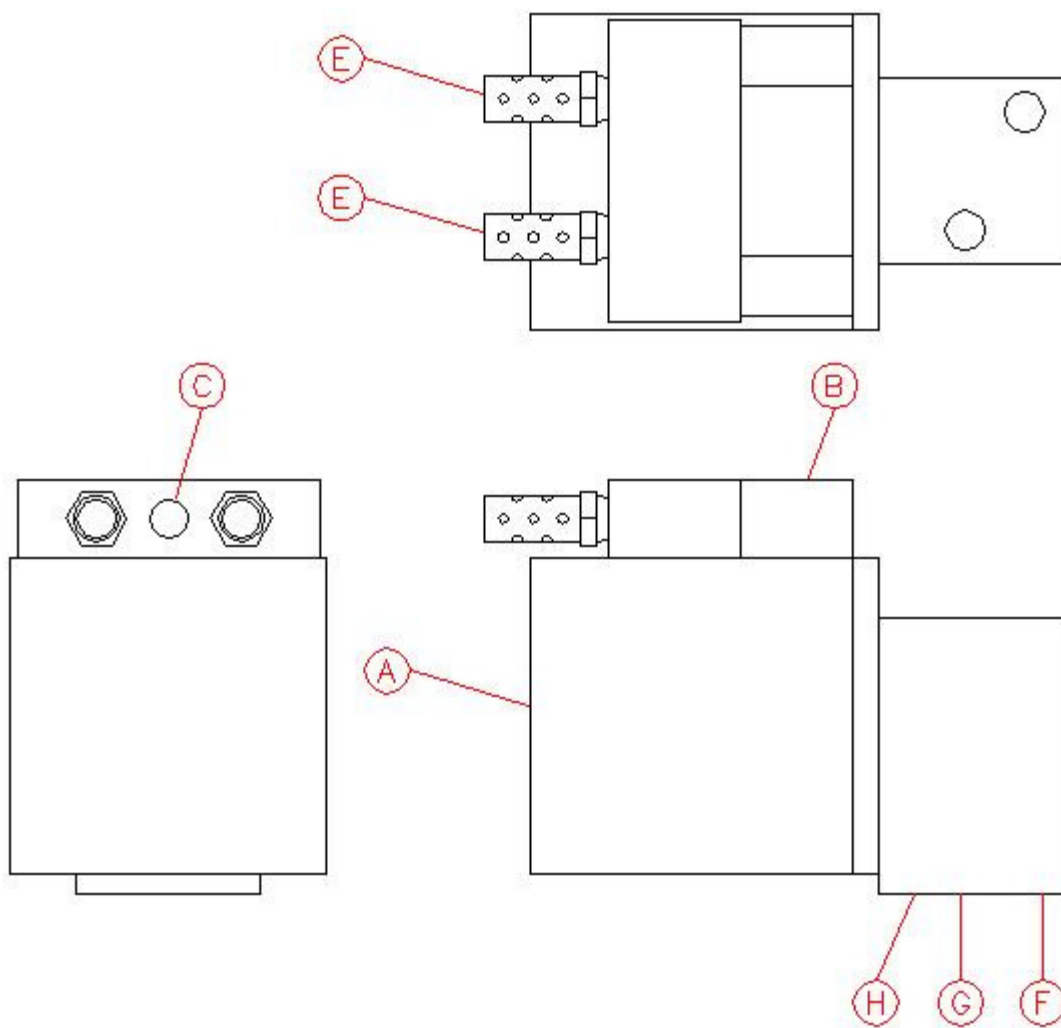

## Start Up Procedures

Oil pressure can be determined by regulation of the compressed air, bearing in mind the multiplication ratio pre-selected for the pump itself and frictional losses.

The models are:	P901 - 06	Nominal Ratio 1 :	6	Actual Ratio 1 :	6.25
	P901 - 10	Nominal Ratio 1 :	10	Actual Ratio 1 :	11
	P901 - 20	Nominal Ratio 1 :	20	Actual Ratio 1 :	19.7
	P901 - 40	Nominal Ratio 1 :	40	Actual Ratio 1 :	42
	P901 - 60	Nominal Ratio 1 :	60	Actual Ratio 1 :	64
	P901 - 80	Nominal Ratio 1 :	80	Actual Ratio 1 :	79
	P901 - 100	Nominal Ratio 1 :	100	Actual Ratio 1 :	100

For instance, when supplied with compressed air at 100 psi, the P901-40 will produce oil pressure of approximately 4,200 psi when completely stalled. It should be remembered that the real hydraulic performance produced by the pump is always slightly less than that given by the theoretical calculation because of small frictional losses from both air and oil seals.

After the pump suction is connected to the oil supply, connect the compressed air supply at a low pressure (20 PSI recommended). Allow the pump to operate slowly until it is primed and oil comes through to the output port or closest circuit connection. Now shut off the air supply to the pump and securely connect to the hydraulic circuit. Switch on the air supply again and allow the pump to run in order to bleed all the air from the hydraulic circuit. With the circuit fully primed, the air supply pressure can be increased to the level required for the intended hydraulic performance.

**Remember to ensure the safety of all persons in the vicinity when this procedure is undertaken and allow for any high-pressure leakage there may be during the testing phase.**



## Fault Finding Chart

<u>Fault</u>	<u>Cause</u>	<u>Remedy</u>
1] Pump does not cycle or only runs slowly.	1.1] Air valve spool stuck in its mid position. 1.2] Formation of ice on the exhaust side.  1.3] Blockage in the muffler or breather.  1.4] Blocked element in air filter/regulator.	1.1] Clear blockage or replace valve assembly. 1.2] Shut off the pump for a short time and drain off water from the filter. 1.3] Remove the muffler/breather, clean or replace. 1.4] Shut off air supply, dismantle and clean filter.
2] Air escaping from muffler or breather.	2.1] Worn air valve or air piston seal.	2.1] Replace valve or seal.
3] Excess oil leakage from muffler/breather.	3.1] Worn hydraulic seal.	3.1] Replace seal.
4] Pump cycles without pumping oil.	4.1] Blocked suction line. 4.2] Bad connection on suction line.  4.3] Check valves blocked or worn.	4.1] Clean out filter. 4.2] Check for bad connections or air leaks on suction line. 4.3] Clean or replace valves.
5] Pump functions but only generates low pressure and does not stall at maximum pressure.	5.1] Internal leakage in the circuit downstream. 5.2] Suction valve seats damaged and leaking. 5.3] Output valve seats damaged and leaking. 5.4] Worn oil seal.	5.1] Find leak source and change component. 5.2] Replace suction valve parts. 5.3] Replace output valve parts. 5.4] Replace seal.

**Maintenance** Periodically release the condensation from the air filter drain. Replace the hydraulic oil every 1500 hours or whenever the oil is polluted. Clean the mufflers on the pump and reservoir periodically. Schedule pump overhauls before seals fail.

**Warning:** Remember that repairs can only be made when pneumatic and hydraulic pressure has been released and you are sure that no pressure remains in the circuit.

## **Transport**

All the material shipped, including the detached parts, has been thoroughly checked before being consigned to the shipping company. The pump is shipped in double corrugated cardboard packaging that assures protection of the product.

## **Unpacking**

On receipt of the product, open the packaging and remove the pump. Take care not to damage any part of the pump. Make an initial check on the pump for damage in transit. In case of damage or if in doubt, do not use the pump and contact Hydronic Corporation or your distributor. The packaging [plastic bags, expanded polystyrene, nails, screws, wood, etc.] must not be left within reach of children since they are potential source of danger. Be sure to dispose of pollutant or non-biodegradable materials in the correct way. Materials must be disposed of in accordance with the laws in force.

## **Gross weight**

P901 ratios - 06, -10, -20	6.6 lbs.
P901 ratios - 40, -60, -80, -100	5.12 lbs.

## **Original spare parts**

Spare parts orders must always be accompanied by the following information:

- A] The pump model      B] The pump serial number      C] The year of manufacture  
(All this data is given on the nameplate)
- D] The part numbers      E] The quantity required      F] The name of the part  
(All this data is given in the parts list)

A clear and correct statement of this data will allow our after-sales service to respond quickly and appropriately. Every spare part must be replaced by professionally qualified staff. The manufacturer declines all responsibility for malfunctions or accidents deriving from any failure of the product when unqualified persons have made any attempt at repair.

**Spare Part Listing** - (refer to drawing overleaf)

Part Number	Quantity	Description
6100	1	Air Cylinder
6101A*	1	Air Valve
6103	1	Air Manifold
6103S*	2	Screws, M3 x 30, 6103 - 6101
6103G*	1	Gasket, 6103 - 6101
6104	2	Screws, Air Manifold to Air Cylinder
6105*	4	O' Rings, Air Manifold to Air Cylinder
6107*	2	Air Muffler
6108	1	Air/Oil Piston Assembly
6109*	2	Seals, Teflon, Air/Oil Piston
6110	1	End Cap, Air Cylinder
6111*	1	O' Ring, End Cap to Air Cylinder
6112	4	Screws, End Cap to Oil Chamber
6113	1	Connector Plate
6114	4	Screws, Connector Plate to Air Cylinder
6115	1	Oil Chamber Assembly
6116*	1	Oil Seal
6117*	2	Check Valves - Old HP Config.
6117O*	2	O' Rings, LP Check Valves - (6-20:1)
6118*	2	Seats, Check Valves - Old HP Config.
6119*	2	Springs, Check Valves - Old HP Config.
6120*	1	O' Ring, End Cap to Oil Piston
6121*	2	O' Rings, Oil Chamber Interface, Nitrile - Old HP Config.
6122	2	Screws, Pump to Manifold
6190*	2	O' Rings, Oil Chamber Interface, Nitrile - New HP Config.
6191*	2	Check Valves - New HP Config.

**Seal Kits:**

Part Number	Ratio
S901-6-X-SK	1:6
S901-10-X-SK	1:10
S901-20-X-SK	1:20
S901-40-X-SK	1:40
S901-60-X-SK	1:60
S901-80-X-SK	1:80
S901-100-X-SK	1:100

\*Included in seal kit

Replace X with seal material (N=Buna, V=Viton)

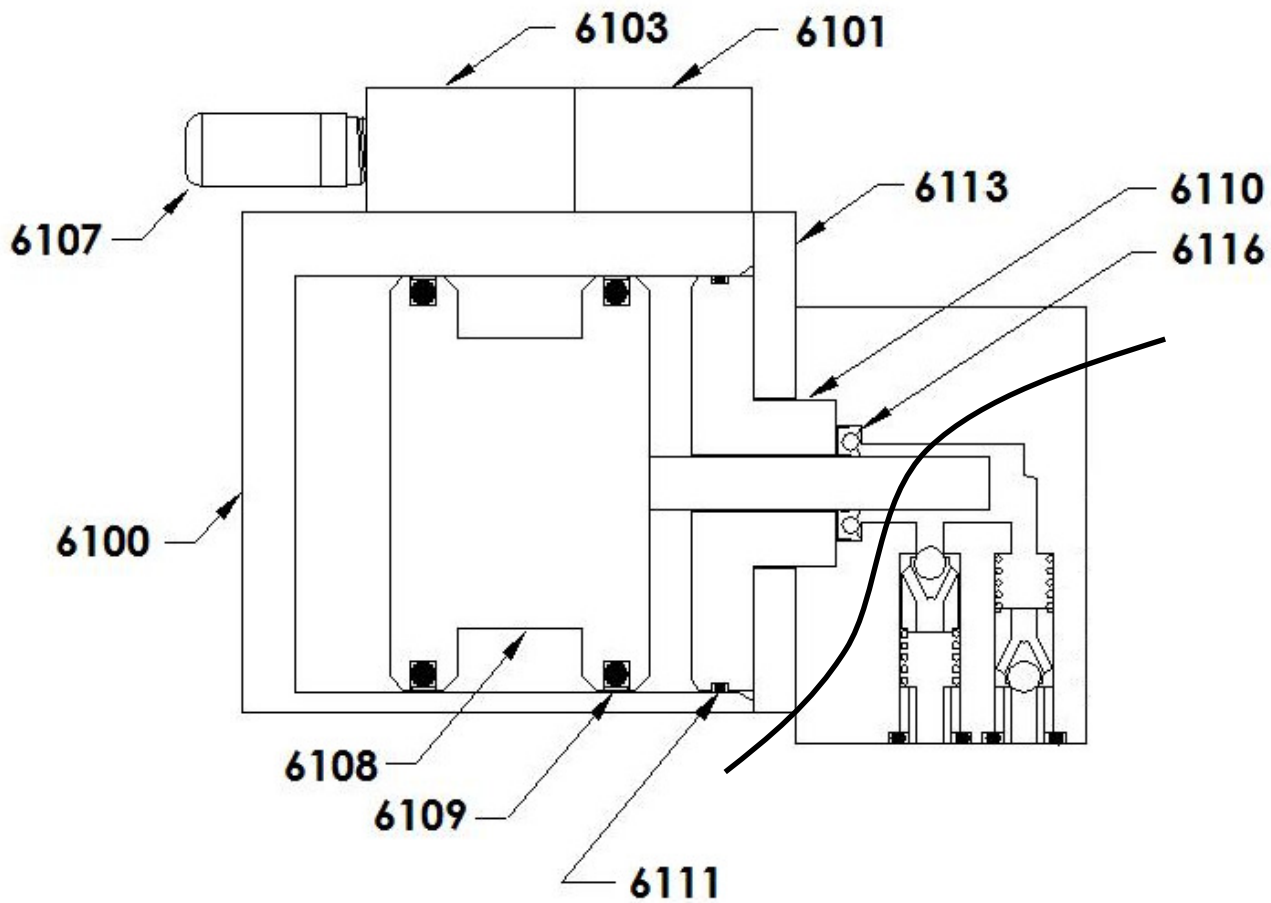

Old HP Check Configuration

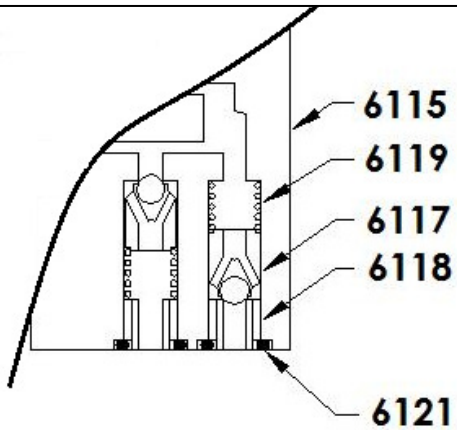

New HP Check Configuration

