

Hydronic Corporation

Air Driven Hydraulic Pumps and Intensifiers

P820 Installation, Use and Maintenance Manual

Contents

Introduction, Guarantee and Identification Plate

Description, Startup Procedures

Description of Working Parts, Storage and Disposal

Fault Finding, Maintenance and Weights

Spare Parts

Hydronic Corporation, 2034 Fruit St, Algonac, MI 48001 United States of America

 (810) 794 4935 www.hydrauliccorp.com

Introduction

This handbook is intended to give the operator the basic instructions for the use and maintenance of the pump. The air hydraulic pump operator must read this handbook before putting the pump into operation. After correctly installing the pump, keep this manual stored in a safe place. If you have difficulty in understanding any part of this handbook, contact Hydronic Corporation. Regular servicing and correct use of the pump are fundamental in obtaining optimum performance over its life. When contacting our service center, specify the pump model and serial number; this will help us to respond quickly and effectively.

Guarantee

Hydronic pumps are guaranteed both for the quality of materials used and for overall design. The warranty runs for six months of normal use at eight hours per day and five days per week. The warranty itself does not cover seals or defects arising out of operating with unsuitable fluids or at pressures above the specified maximum. The guarantee cannot cover pumps that may have been tampered with. Defective goods must be sent to Hydronic Corporation at Farmington Hills or to the distributor covering the area, freight pre-paid in either case. Any pump returned to us must be accompanied by a full written description of such faults or defects as have been discovered. Please also ensure that the pump's serial number is attached to the paperwork.

Identification Plate

- 1 Pump model and intensification ratio
- 2 Serial number pump
- 3 Maximum air pressure
- 4 Maximum working oil pressure allowed
- 5 Year of construction

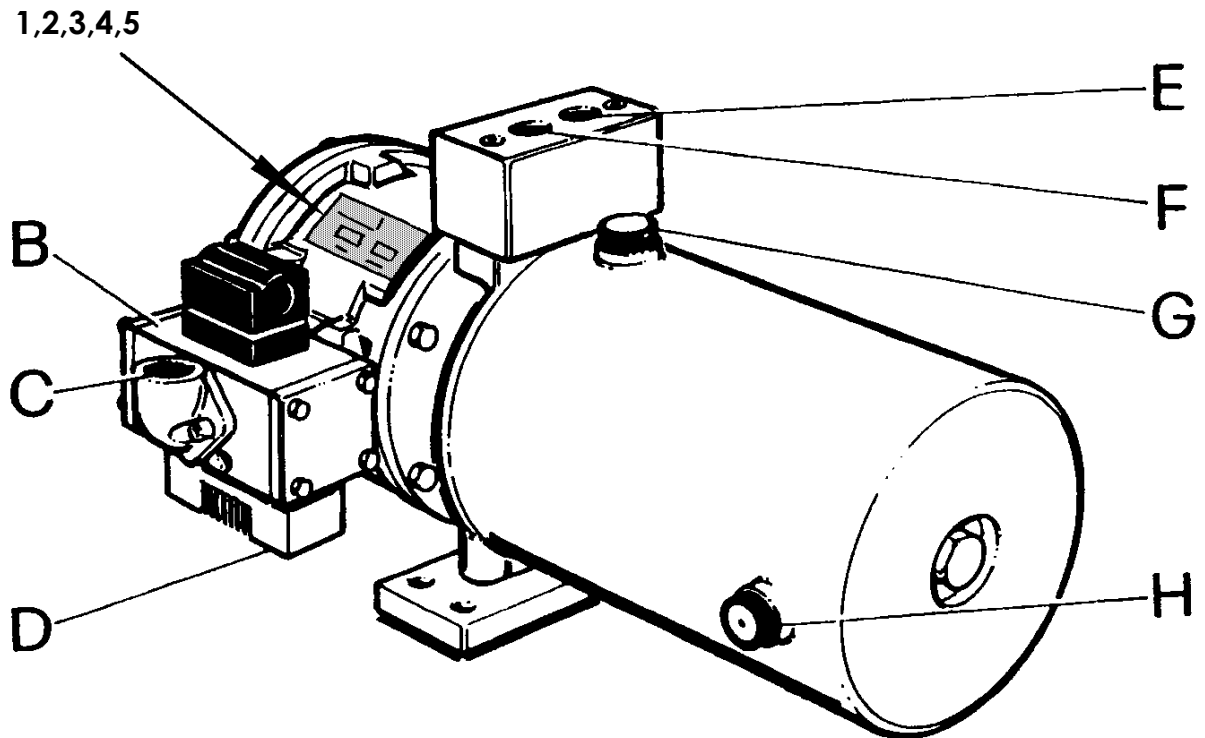

Installation Guide

Pumps may be installed in a horizontal or vertical position for optimum functioning of suction and delivery valves. The round reservoir may be used horizontally and it is advised that the breather and sight glass be interchanged and/or the reservoir rotated to allow the breather to remain uppermost. The suction and return tubes inside the reservoir may also be rotated to ensure fluid is taken from, and returned to, the bottom of the reservoir in any given position.

The air inlet connection can be rotated at 90 ° and piping of not less than 3/8" bore should be used. 1/2" should be used if the pump is to be run at higher speeds for greater flows.

It is advisable to use or maintain:

- Hydraulic oil having viscosity of 150 to 250 SSU
- Oil temperature 32° F to 150° F
- Air temperature 40° F to 100° F
- Room temperature 40° F to 100° F

Obstructive icing of the silencer may occur under certain temperature/humidity conditions. This can be remedied by the addition of antifreeze oil for pneumatic equipment to a mist lubricator.

Compressed Air System

It will be advisable to fit an air filter/regulator unit having minimum flow capacity of 50 scfm with an air pressure gauge to ensure the pump has sufficient air energy to work correctly and provide the hydraulic performance you expect.

Hydraulic System

Valves, pipes, hoses and accessories should all correspond to maximum working pressure of the pump used and be of a size that will fulfill flow requirements.

Application

Hydronic air driven hydraulic pumps are designed for operating oil hydraulic circuits and to cover the widest range of requirements to the best advantage. The pump itself operates quite simply, using a known pressure intensification principle. A piston with a large surface area is actuated by compressed air. Attached to it is a piston with a smaller surface area, which is driven in a hydraulic chamber generating a high level of hydraulic pressure. The continuous pumping action is produced by the compressed air being switched by a special sealless spool valve. By regulating the compressed air supply pressure from 30 psi to 100 psi, the maximum hydraulic pressure can be adjusted by the ratio of the pump used. As the hydraulic load of the circuit increases and the oil pressure rises, the pump will slow down and eventually stop. In this way, the maximum load of the circuit will be maintained without air consumption.

Storage

If the pump is to be kept out of use for a long period, clean the pump in general and drain the oil from the tank. Cover the pump and store it in a dry, well-protected place. It is advisable to wrap the pump in a plastic film. To put back into service, check all parts, fill tank with oil and try the pump out to ensure that it working properly. **This operation must be carried out by qualified personnel.**

Disposal

If the pump is to be scrapped, treat as a special type of waste. Dismantle it and divide it into materials of the same type and dispose of them in accordance with the local laws and regulations in your state.

Description of the standard pump components

- A Air valve
- B Oil outlet #8 SAE
- C Oil return #8 SAE
- D Oil filler plug
- E Oil level sight glass

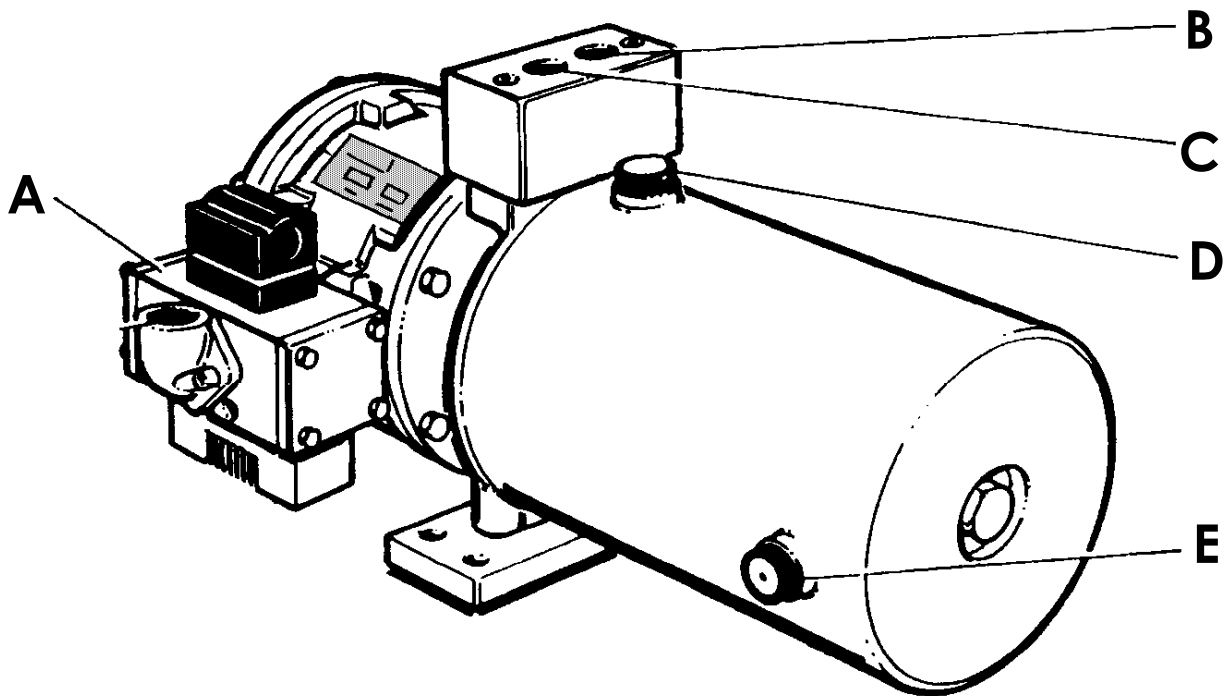

Starting - Up

Oil pressure can be determined by regulation of the compressed air, bearing in mind multiplication ratio pre-selected for the pump itself.

The models are: P820 RATIO 1:5
P820 RATIO 1:10
P820 RATIO 1:20
P820 RATIO 1:30
P820 RATIO 1:40

For instance, when supplied with compressed air at 80 psi, the P820-5 will produce oil pressure of 80 x ratio, 400 psi. It should be remembered that actual efficiency produced by the pump is slightly less than given by the above theoretical calculation. This difference will not be noticed by a hydraulic gauge.

Having connected the compressed air supply at a low pressure, allow the pump to operate slowly until primed and oil comes through to the oil output port. Now shut off the air supply to the pump and securely connect the hydraulic circuit. Switch on the air supply again and allow the pump to run in order to bleed any air out of the hydraulic circuit.

Pump features:

- Standard manifolds and subplates are available with various configurations of SAE threaded ports for output and return as well as D03 interfaces.
- Optional rotation of the 1/2" NPT air inlet elbow in four positions.
- The pump itself works automatically and operates by way of an integral valve.
- The pneumatic drive section has graphite filled seals for minimum friction, no lubrication requirement and long life.
- The hydraulic section comprises an alloy steel pump casing, hard chrome plated piston rod and bronze filled seals.
- The suction side of the pump is equipped with a spring-loaded check valve. A spring-loaded outlet ball type check valve is incorporated in the hydraulic piston.

Fault Finding Chart

Fault	Cause	Remedy
1] Pump does not cycle or runs slowly.	1.1] Low pressure in compressed air line.	1.1] Clear any blockage or restriction on the air line.
	1.2] Formation of ice on the exhaust side.	1.2] Shut off pump for a short time and drain off water from the filter.
	1.3] Accumulation of waste in the silencer.	1.3] Remove silencer, clean and replace.
	1.4] Blocked element in air filter/regulator.	1.4] Close down air-supply, dismantle and clean filter.
2] Pump loses air from silencer when stalled.	2.1] Worn valve or seal	2.1] Replace seal or valve.
3] Excess oil leakage from air silencer.	3.1] Worn hydraulic seal	3.1] Replace seal.
4] Pump cycles without pumping oil.	4.1] Blocked oil-intake	4.1] Clean out filter.
	4.2] Bad connection on suction line.	4.2] Check for bad connections or air leaks on suction line.
5] Pump functions but only generates low pressure and does not stall at max. pressure.	5.1] Internal leakage in the circuit.	5.1] Find leak source and change valve.
	5.2] Suction valve seats damaged and leaking.	5.2] Replace suction valve parts.
	5.3] Output valve seats damaged and leaking.	5.3] Replace output valve parts.
	5.4] Worn oil seal.	4.4] Replace seal.

Maintenance

Periodically release the condensation from the air filter. Replace the hydraulic oil every 1500 hours or whenever the oil is polluted.

Warning: Remember that repair work can only be made when pneumatic and hydraulic pressure has been released and you are sure that no pressure remains in the circuit.

Delivery of the pump

Transport

All the material shipped, including the detached parts, has been thoroughly checked before being consigned to the forwarding agent. The pump is shipped in double corrugated cardboard packaging, which assures protection of the product.

Unpacking

On receipt of the product, open the packaging and remove the pump. Take care not to damage any part of the pump. Make an initial check on the pump for damage in transit. In case of damage or if in doubt, do not use the pump and contact Hydronic Corporation or your distributor. The packaging [plastic bags, expanded polystyrene, nails, screws, wood, etc.] must not be left within reach of children since they are potential source of danger. Be sure to dispose of pollutant or non-biodegradable materials in the correct way. Materials must be disposed of in accordance with the laws in force.

Approximate gross weight

P820 standard reservoir	33 lbs.
P828 large reservoir	44 lbs.

Contents of the package

The packaging will always contain the following:

- 1 x air driven hydraulic pump
- 1 x installation, use and maintenance manual

Original spare parts

Parts orders must always be accompanied by the following information:

- A] The pump model B] The pump serial number C] The year of construction
(all this data is given on the nameplate)
- D] The part numbers E] The quantity required F] The name of the part
(All this data is given in the parts list)

A clear and correct statement of this data will allow our after-sales service to respond quickly and appropriately. Every spare part must be replaced by professionally qualified staff. The manufacturer declines all responsibility for malfunctions or accidents deriving from any failure of the product when unqualified persons have made any attempt at repair.

Pump Exploded View

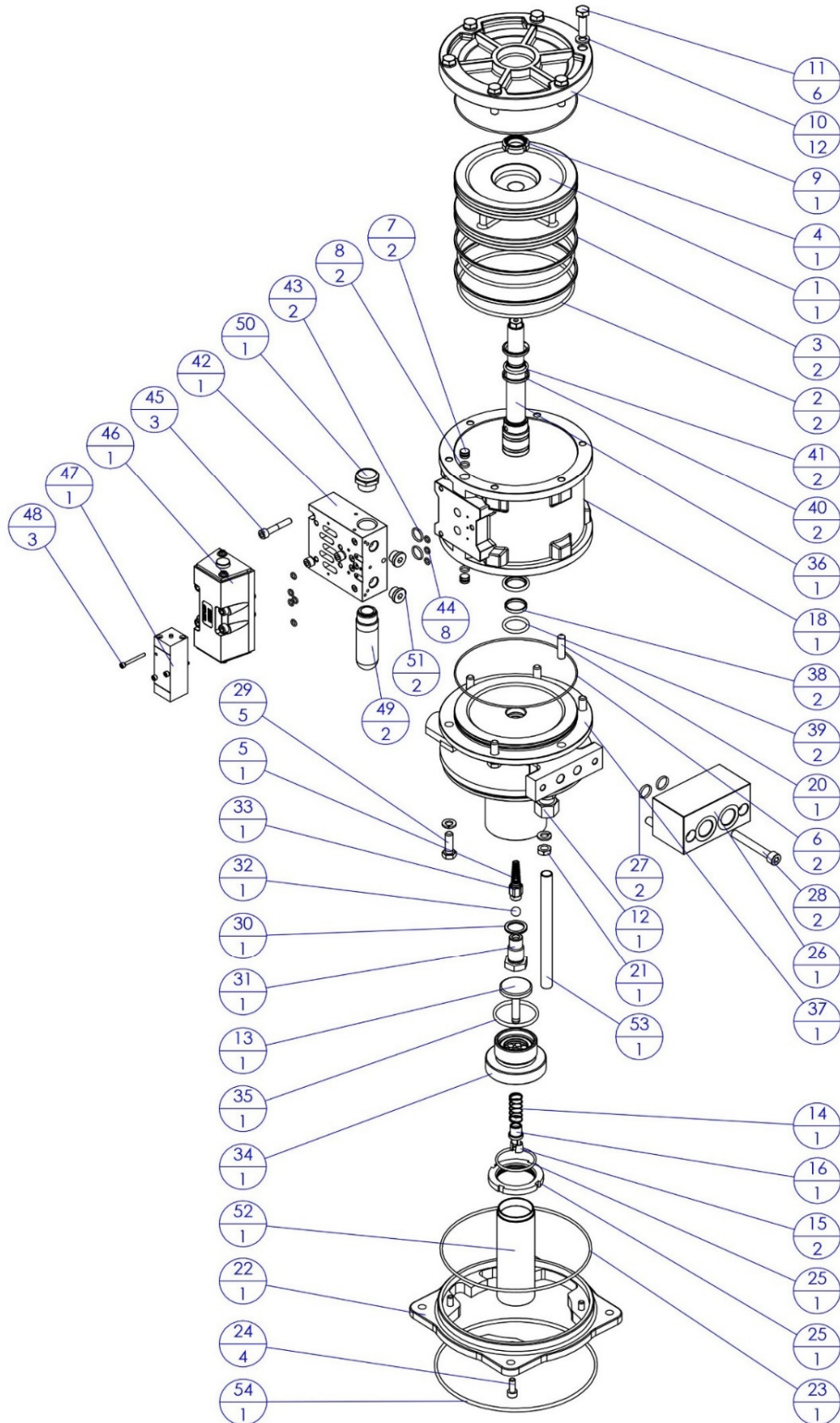

ITEM	SEAL KIT	PART NUMBER	CODE	QTY	DESCRIPTION
1		S820-XX-N-18	5.068.0045	1	PNEUMATIC PISTON P820 - ϕ 130
2	*	S820-XX-N-100	3.051.0077	2	O-RING 2-247/4462
3	*	S820-XX-N-16	3.051.0076	2	RING
4		S820-XX-N-17	3.045.0204	1	SELF-LOCKING NUT
5		S820-5/10-N-31	5.064.0028	1	SPRING P820-5-10
5		S820-20/30/40-N-31	5.064.0029	1	SPRING P820-20-30-40
6	*	S820-XX-N-15	3.051.0075	2	O-RING 2-49/2500
7		S820-XX-N-20	5.084.0002	2	PLUG
8	*	S820-XX-N-21	3.051.0083	2	O-RING 2-10/205
9		S820-XX-N-9	5.086.0006	1	FRONT HEAD PUMP
10		S820-XX-N-105	3.072.0104	12	SPRING WASHER - ϕ 8
11		S820-XX-N-26	3.094.0208	6	SCREW M8x30 - UNI5739
12		S820-XX-N-47	3.070.0006	1	CONNECTOR BSP 1/4"x12
13		S820-XX-N-36	5.066.0011	1	VALVE SUCTION BOLT
14		S820-XX-N-39	5.064.0030	1	SUCTION SPRING
15		S820-XX-N-41	3.006.0006	2	SEMICONE
16		S820-XX-N-40	5.013.0008	1	SUCTION CENTERING - P820
18		S820-XX-N-19	5.018.0030	1	JACKET P820
20		S820-XX-N-108	3.094.0404	1	GRAIN M8x30 -UNI5927
21		S820-XX-N-102	3.031.0016	1	LOCK NUT
22		A820-XX-N-STF	5.042.0002	1	FLANGE
23	*	2-163	3.051.0078	1	O-RING 2-162/3575
24		C00500-013	3.094.0008	4	SCREW M6x16 - UNI5931
25		S820-XX-N-43	3.045.0212	1	RING NUT M40x1,5
26		-	-	1	MANIFOLD WILL VARY DEPENDING ON OPTIONS
27	*	C02500-014	3.051.0109	2	O-RING 2-14/2050
28		C00590-088	3.094.0010	2	SCREW M8x50 - UNI5931
29		S820-XX-N-29	3.094.0207	5	SCREW M8x25 - UNI5739
30	*	S820-5/10-N-34	3.052.0010	1	DOWTY ϕ 30 P820-5-10
30		S820-20/30/40-N-34	3.052.0003	1	DOWTY 3/8" BSP P820-20-30-40
31		S820-5/10-N-35	5.094.0303	1	SCREW VALVE SEAT P820-5-10
31		S820-20/30/40-N-35	5.094.0302	1	SCREW VALVE SEAT P820-20-30-40
32		S820-5/10-N-33	3.076.0006	1	BALL ϕ 18,25 P820-5-10
32		S820-20/30/40-N-33	3.076.0002	1	BALL ϕ 10 P820-20-30-40
33		S820-5/10-N-32	5.046.0007	1	CENTERING P820-5-10
33		S820-20/30/40-N-32	5.046.0006	1	CENTERING P820-20-30-40
34		S820-5/10-N-38	5.028.0032	1	SUCTION BODY VALVE P820-5-10
34		S820-20/30/40-N-38	5.028.0031	1	SUCTION BODY VALVE P820-20-30-40
35	*	S820-5/10-N-37	3.051.0127	1	O-RING 2-235/4312 P820-5-10
35	*	S820-20/30/40-N-37	3.051.0055	1	O-RING 2-223/4162 P820-20-30-40
36		S820-5-N-29	5.068.0049	1	HYDRAULIC PISTON P820-5
36		S820-10-N-29	5.068.0048	1	HYDRAULIC PISTON P820-10

ITEM	SEAL KIT	PART NUMBER	CODE	QTY	DESCRIPTION
36		S820-20-N-29	5.068.0047	1	HYDRAULIC PISTON P820-20
36		S820-30-N-29	5.068.0177	1	HYDRAULIC PISTON P820-30
36		S820-40-N-29	5.068.0046	1	HYDRAULIC PISTON P820-40
37		S820-5-N-25	5.028.0030	1	PUMP BODY P820-5
37		S820-10-N-25	5.028.0029	1	PUMP BODY P820-10
37		S820-20-N-25	5.028.0028	1	PUMP BODY P820-20
37		S820-30-N-25	5.028.0057	1	PUMP BODY P820-30
37		S820-40-N-25	5.028.0027	1	PUMP BODY P820-40
38	*	S820-5-N-23	3.051.0088	2	BODY SEAL P820-5
38	*	S820-10-N-23	3.051.0086	2	BODY SEAL P820-10
38	*	S820-20-N-23	3.051.0085	2	BODY SEAL P820-20
38	*	S820-30-N-23	3.051.0234	2	BODY SEAL P820-30
38	*	S820-40-N-23	3.051.0011	2	BODY SEAL P820-40
39	*	-	3.051.0089	2	O-RING 2-333/6250 P820-5 - INCLUDED WITH S820-5-N-23
39	*	-	3.051.0087	2	O-RING 2-328/6187 P820-10 - INCLUDED WITH S820-10-N-23
39	*	-	3.051.0014	2	O-RING 2-217/4118 P820-20 - INCLUDED WITH S820-20-N-23
39	*	-	3.051.0057	2	O-RING 2-214/4100 P820-30 - INCLUDED WITH S820-30-N-23
39	*	-	3.051.0010	2	O-RING 2-212/4087 P820-40 - INCLUDED WITH S820-40-N-23
40	*	S820-5-N-30	3.051.0096	2	PISTON SEAL P820-5
40	*	S820-10-N-30	3.051.0094	2	PISTON SEAL P820-10
40	*	S820-20-N-30	3.051.0092	2	PISTON SEAL P820-20
40	*	S820-30-N-30	3.051.0173	2	PISTON SEAL P820-30
40	*	S820-40-N-30	3.051.0090	2	PISTON SEAL P820-40
41	*	-	3.051.0097	2	O-RING 5-703/168 P820-5 - INCLUDED WITH S820-5-N-30
41	*	-	3.051.0095	2	O-RING 2-224/4175 P820-10 - INCLUDED WITH S820-10-N-30
41	*	-	3.051.0093	2	O-RING 2-123/3118 P820-20 - INCLUDED WITH S820-20-N-30
41	*	-	3.051.0033	2	O-RING 2-119/3093 P820-30 - INCLUDED WITH S820-30-N-30
41	*	-	3.051.0091	2	O-RING 2-117/128 P820-40 - INCLUDED WITH S820-40-N-30
42		7.078.0020-NPT	7.078.0020-NPT	1	AIR VALVE BLOCK 1/2" NPT
43	*	C02500-014	3.051.0109	2	O-RING 2-14/2050
44		C02500-008	3.051.0130	8	O-RING 2-8/2018
45		C00500-112	3.094.0026	3	SCREW M6x35 - UNI5931
46		S820-XX-N-NAV	4.091.0020	1	PNEUMATIC VALVE

ITEM	SEAL KIT	PART NUMBER	CODE	QTY	DESCRIPTION
47		S820-XX-N-136	4.091.0028	1	BISTABLE MEMORY
48		S901-XX-N-6103S	3.094.0061	3	SCREW M3x30 - UNI5931
49		S820-XX-N-138	3.070.0096	1	SILENCER 1/2"
50		S820-XX-N-139	3.070.0068	1	SILENCER 1/2"
51		S820-XX-N-140	3.070.0028	2	PLUG MALE 1/4"
52		A820-XX-N-50	5.090.0025	1	SUCTION PIPE
53		A820-XX-N-49	5.090.0024	1	DISCHARGE OIL PIPE
54	*	C02500-260	3.051.0237	1	O-RING 2-260/4650

Seal Kits

ITEM		CODE	CODE	QTY	DESCRIPTION
	*	S820-5-N-SK	3.054.0028	1	S820-5 SEAL KIT
	*	S820-10-N-SK	3.054.0029	1	S820-10 SEAL KIT
	*	S820-20-N-SK	3.054.0030	1	S820-20 SEAL KIT
	*	S820-30-N-SK	3.054.0080	1	S820-30 SEAL KIT
	*	S820-40-N-SK	3.054.0031	1	S820-40 SEAL KIT